

Very narrow aisle truck 1.0 - 1.5 ton



BT vector

A-series

VCE100A

VCE120A

VCE150A

VCE125ASF

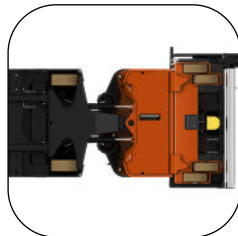

Very Narrow Aisle truck

Specifications				VCE100A	VCE120A	VCE150A	VCE125ASF	
Identification	1.1	Manufacturer		Toyota	Toyota	Toyota	Toyota	
	1.2	Model		VCE100A	VCE120A	VCE150A	VCE125ASF	
	1.3	Drive		Electric	Electric	Electric	Electric	
	1.4	Operator type		Seated	Seated	Seated	Seated	
	1.5	Load capacity/rated load	Q	kg	1000	1200	1500	1250
	1.6	Load centre	c	mm	600	600	600	600
	1.9	Wheelbase	y	mm	1655	1655	1655	1655
Weight	2.1	Service weight without battery		kg	6150*	6170*	6920*	6920*
	2.2	Axle load, with load, drive/support arm wheel		kg	3825/4725	3930/5030	4303/5795	4303/5795
	2.3	Axle load, without load, drive/support arm wheel		kg	4410/3135	4630/3125	5182/3415	5182/3415
Wheels	3.1	Drive/support arm wheel			Vulkollan	Vulkollan	Vulkollan	Vulkollan
	3.2	Wheel size, front		mm	∅ 300x100	∅ 300x100	∅ 300x100	∅ 300x100
	3.3	Wheel size, rear		mm	∅ 350x128	∅ 50x128	∅ 350x128	∅ 350x128
	3.5	Wheels, number front/rear (x = driven wheels)				4/2x	4/2x	4/2x
	3.6	Track width, front	b ₁₀	mm	1008/1158	1008/1158/1258/ 1358/1438	1008/1158/1258/ 1358/1438	1008/1158/1258/ 1358/1438
	3.7	Track width, rear	b ₁₁	mm	1010	1010	1010	1010
	Dimensions	4.2	Height, mast lowered	h ₁	mm	4405*	4405*	4450*
4.4		Lift movement	h ₃	mm	5730*	5730*	8190*	8190*
		Total lift height	h ₂₃	mm	7800*	7800*	10250*	10250*
4.5		Height, mast extended	h ₄	mm	8511*	8511*	10961*	10961*
4.7.1		Height of overhead guard (cabin)	h ₆	mm	2544	2544	2544	2544
4.7.2		Height of cabin inside	h ₂₁	mm	2060	2060	2060	2060
4.7.3		Height of cabin sides	h ₂₂	mm	900	900	900	900
4.7.4		Carpet thickness		mm	17,5	17,5	17,5	17,5
4.8		Step-in height	h ₇	mm	412	412	412	412
4.11		Additional lift	h ₉	mm	1990/2590	1990/2590	1990/2590/3090	1990/2590/3090
4.14		Platform height, elevated	h ₁₂	mm	6150*	6150*	8600*	8600*
4.15		Height of lowered forks	h ₁₃	mm	80	80	80	350
		Height of auxiliary lift mast	h ₁₅	mm	2781/3381	2781/3381	2781/3381/3941	2781/3381/3941
4.19		Overall length	l ₁	mm	3846	3846	3846	3846
4.20		Length to face of forks	l ₂	mm	3616	3616	3616	3179
4.21.1		Chassis width, rear	b ₁	mm	1270	1270	1270	1270
4.21.2		Chassis width, front	b ₂	mm	1270/1420	1270/1420	1270/1420/1520/ 1620/1700	1270/1420/1520/ 1620/1700
4.21.3		Cabin width	b ₂₄	mm	1220-1670	1220-1670	1220-1820	1220-1570
4.22		Fork dimensions	s	mm	40/45	40/45	40/45	65
			e	mm	120/125	120/125	120/125	180
		l	mm	600-1800	600-1800	600-1800	1200-1450	
4.25	Width over forks	b ₅	mm	min 380, max 793	min 380, max 793	min 380, max 793/1193/1493	550	
4.31	Ground clearance, with load, below mast	m ₁	mm	60	60	60	60	
	Turning radius	W _A	mm	1698	1698	1698	1698	
4.38	Distance front axle to boom pivot	l ₈	mm	830-1080	830-1080	830-1830	1127/1227/1327	
	Entrance width, min/max	l ₂₄	mm	398	398	398	398	
Performance data	5.1	Travel speed, with/without load		km/h	9,0/9,0	9,0/9,0	10,0/12,0	10,0/12,0
	5.2	Lift speed, with/without load		m/s	0,40/0,45	0,40/0,45	0,40/0,45	0,40/0,45
	5.3	Lowering speed, with/without load		m/s	0,40/0,40	0,40/0,40	0,40/0,40	0,40/0,40
	5.10	Service brake			Electric	Electric	Electric	Electric
	5.11	Parking brake			Electro-mechanical	Electro-mechanical	Electro-mechanical	Electro-mechanical
	Electric motor	6.1	Drive motor rating S2 60 min		kW	2x5,5	2x5,5	2x5,5
6.2		Lift motor rating S3 25%		kW	14,5	14,5	14,5	14,5
6.4		Battery voltage, nominal capacity K ₅		V/Ah	48/930	48/1050*	48/1240*	48/1240*
6.5		Battery weight		kg	1300	1425*	1790*	1790*
8.1		Type of drive control			Variable AC	Variable AC	Variable AC	Variable AC

* Other dimensions available.

All data are based on table configuration. Other configurations may give other values.
Truck performance and dimensions are nominal and subject to tolerances.
Toyota Material Handling products and specifications are subject to change without notice.

Note 1: The measure is to a point between the double wheels.
Note 2: An imaginary line halfway between the double wheels.

Mast dimensions

BT vector

Mast				Duplex Tele Mast					
VCE100A/120A	Platform height		h_{12}	mm	3550	5150	6150	7750	8850
	Picking height		h_{28}	mm	5150	6750	7750	9350	10450
	Height, mast lowered		h_1	mm	3150	3950	4405	5405	5955
	Total lift height	Auxiliary mast $h_9 = 1990$	h_{23}	mm	5200	6800	7800	9400	10500
		Height, mast extended	h_4	mm	5911	7511	8511	10111	11211
		Auxiliary mast $h_9 = 2530$	h_{23}	mm	5740	7340	8340	9940	11040
		Height, mast extended	h_4	mm	6451	8051	9051	10651	11751

Mast				Triplex Tele Mast												
VCE125ASF/150A	Platform height		h_{12}	mm	4100	4700	5300	6050	7400	8600	9800	11000	11600	12650	14050	
	Picking height		h_{28}	mm	5700	6300	6900	7650	9000	10200	11400	12600	13200	14250	15650	
	Height, mast lowered		h_1	mm	2790	2960	3160	3460	3960	4460	4960	5460	5660	6040	6200	
	Total lift height	VCE125ASF	Auxiliary mast $h_9 = 750$	h_{23}	mm	4790	5390	5990	6740	8090	9290	10490	11690	12290	13340	n/a
		VCE150A	Auxiliary mast $h_9 = 1990$	h_{23}	mm	5750	6350	6950	7700	9050	10250	11450	12650	13250	14300	n/a
			Height, mast extended	h_4	mm	6461	7061	7661	8411	9761	10961	12161	13361	13961	15011	n/a
			Auxiliary mast $h_9 = 2530$	h_{23}	mm	n/a	n/a	7490	8240	9590	10790	11990	13190	13790	14840	n/a
			Height, mast extended	h_4	mm	n/a	n/a	8201	8951	10301	11501	12701	13901	14501	15551	n/a
			Auxiliary mast $h_9 = 3090$	h_{23}	mm	n/a	n/a	n/a	n/a	n/a	n/a	n/a	n/a	n/a	n/a	16800
	Height, mast extended	h_4	mm	n/a	n/a	n/a	n/a	n/a	n/a	n/a	n/a	n/a	n/a	17511		

h_{12} = cabin floor height, calculated from cabin floor height 410 mm for lowered cabin.

Dimensional drawings

BT vector

VCE100A, VCE120A, VCE150A

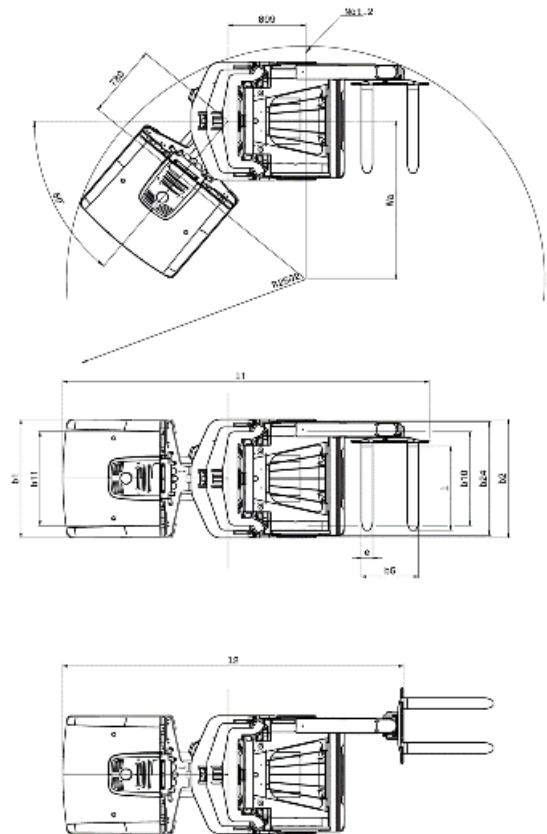
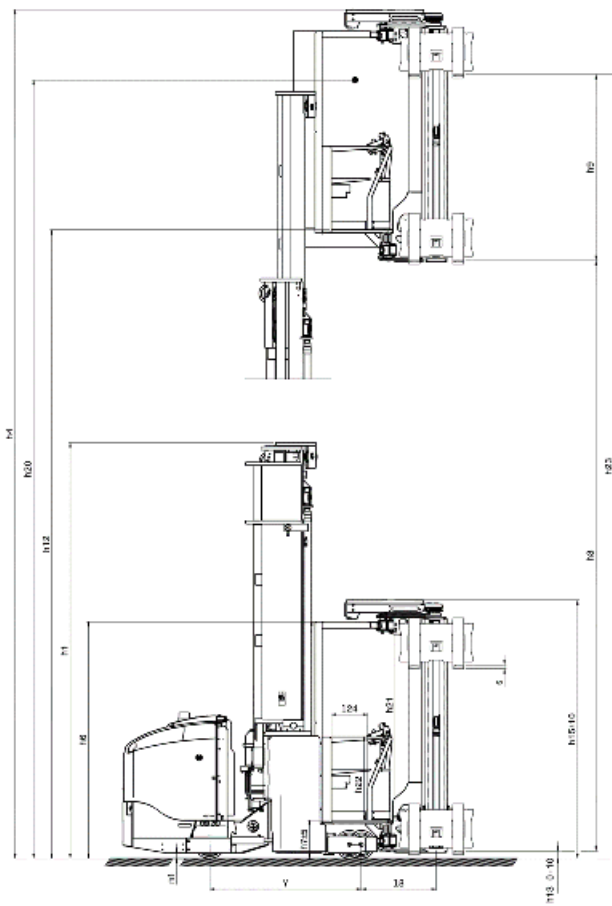

VCE125ASF

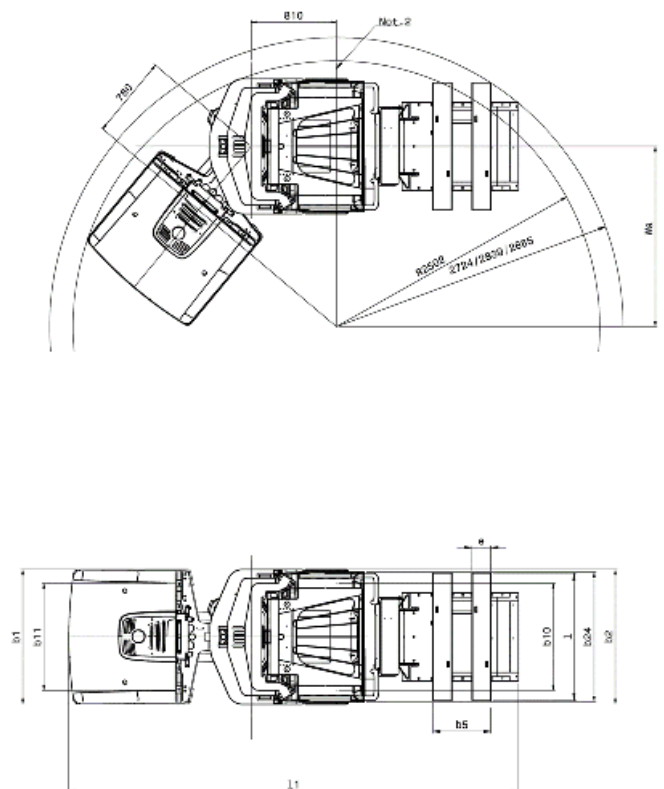
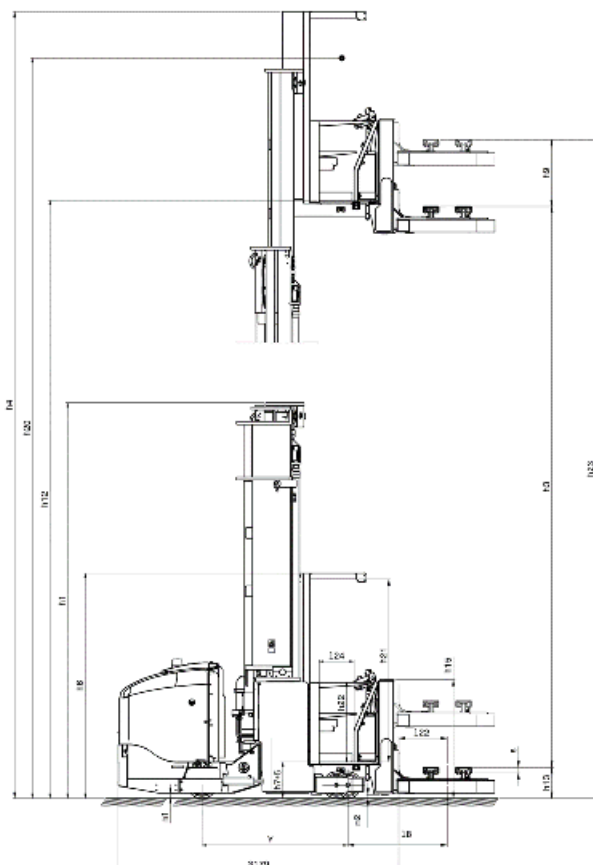

Truck features:

- Articulated steering
- Four wheeled chassis
- Twin drive units
- Quadset support wheels
- Personal protection system (option)
- Beltdriven fork movement
- Advanced lifting system (VCE150A/125ASF)

